



DIESEL GENERATOR SET INSTRUCTION MANUAL



APD9500Q



APD11000Q



APD13000Q

INTRODUCTION

Dear Customers,

Thank you for purchasing soundproof diesel generator. This manual must be read and understood prior to operating the generator.

SAVE THIS MANUAL. Keep this manual for the safety warning and precautions, assembly, operating, inspection, maintenance and cleaning procedures. With proper use and maintenance, this generator will bring years of satisfying service.

line technology is constantly expanding with new models.

products are characterized by ergonomic design; ensure the convenience of its use, smart design, high performance. In endless pursuit of integrity and profession with the spirit of innovation and excellence, shows you the best power solution, guides you to new life experience.

Due to changes in the technical specification, the content of this manual may not fully comply with.

We reserve the right to make changes in a construction of individual parts without prior notice.

Diesel Generator Set

Model	APD9500Q	APD11000Q	APD13000Q
Phase	Single/Three/Equal power		
Frequency/Hz	50	50	50
Max. power/KW	6.5	7.5	11
Rated power/KW	6.0	7.0	10
AC voltage/V	230/400	230/400	230/400
Engine model	192FE	198FE	2V88B
Rotating speed/rpm	3000	3000	3000
Bore×stroke/mm	92×75	98×84	2x88x73
Displacement/CC	498	633	870
Lubrication method	Pressure and splash compound type		
Oil volume/L	1.65	1.65	2.3
Fuel type	Diesel (summer 0#/winter -10#)		
Fuel tank volume/L	12.5	15	26
Working temperature/°C	≤40	≤40	≤40
Noise level/dB@7m	75-82	75-82	80-86
Gross weight/kg	170-175	190-195	260-265
Package outer diameter/mm	965×570×800 (Pallet height 80)	1120×630×835 (Pallet height 110)	1310×730×910 (Pallet height 110)

The specific parameters are subject to update without notice.

RECOGNIZE SAFETY SYMBOLS, WORDS AND LABELS

What You Need to Know About Safety Instructions

Warning and Important Safety Instructions appearing in this manual are not meant to cover all possible conditions and situations that may occur. Common sense, caution and care must be exercised when operating or cleaning tools and equipment.

Always contact your dealer, distributor, service agent or manufacturer about problems or conditions you do not understand.



This is the safety alert symbol. It is used to alert you to potential personal injury hazards. Obey all safety messages that follow this symbol to avoid possible injury or death.



DANGER indicates an imminently hazardous situation which, if not avoided, will result in death or serious injury.



WARNING indicates a potentially hazardous situation which, if not avoided, could result in death or serious injury.



CAUTION indicates a potentially hazardous situation which, if not avoided, may result in minor or moderate injury.



CAUTION used without the safety alert symbol indicates a potentially hazardous situation which, if not avoided, may result in property damage.

Add Diesel Fuel ONLY (DO NOT ADD GASOLINE)

USE THIS GENERATOR ONLY OUTDOORS IN NON-CONFINED AREAS. DO NOT SECURE THE GENERATOR WITH A CHAIN OR ROPE, AS THIS WILL MAKE IT DIFFICULT TO MOVE IN AN EMERGENCY.

IMPORTANT SAFETY INSTRUCTIONS

STOP!

⚠ DANGER

Carbon Monoxide Gas: When in operation, the exhaust from this generator contains poisonous carbon monoxide gas. Carbon monoxide gas is both odorless and colorless AND may be present even if you do not see or smell gas. Breathing this poison gas can lead to headaches, dizziness, drowsiness, loss of consciousness and eventually death.

- USE THIS GENERATOR ONLY OUTDOORS IN NON-CONFINED AREAS. DO NOT SECURE THE GENERATOR WITH A CHAIN OR ROPE, AS THIS WILL MAKE IT DIFFICULT TO MOVE IN AN EMERGENCY.
- Keep at least several feet of clearance on all sides to allow proper ventilation for this generator.

⚠ WARNING

Chemicals: The exhaust from this generator contains chemicals known to cause cancer, birth defects, or other reproductive harm.

⚠ WARNING

Flammable Fuel: This generator may emit highly flammable and explosive fuel vapors, which can cause severe burns or even death. A nearby open flame can lead to an explosion even if not directly in contact with fuel.

- Do not operate this generator near open flame.
- Do not smoke near this generator.
- Always operate this generator on a firm, level surface.

Diesel Fuel is highly flammable and explosive. Handling fuel can result in serious injury or burns.

- Always shut down this generator before refueling. Refuel in a well-ventilated area. Keep heat, sparks and flame away while refueling and away from the location where diesel fuel is stored. Never refuel indoors where diesel fuel fumes may reach flames and/or sparks.
- Allow this generator to cool for at least 2 minutes before removing the fuel tank cap. Loosen the cap slowly to relieve pressure in the fuel tank. Avoid spilling fuel.
- Do not fill the fuel tank above the upper limit line. Diesel fuel may expand during operation. Do not fill to the top of the tank.
- Always check for spilled diesel fuel and immediately wipe it up before starting this generator.
- Empty the fuel tank before storing or transporting this generator.
- Always handle fuel outdoors.
- Before transporting, turn the fuel valve to the "OFF" position.

⚠ DANGER

Powerful Voltage: This generator produces powerful voltage, which can result in electrocution.

- ALWAYS ground this generator before using it. (See "Ground the Generator" section in this manual).
- Only electrical devices should be plugged into this generator, either directly or with an extension cord. NEVER connect a building electrical system to this generator without a qualified electrician. Such connections must isolate generator power from utility power and comply with local electrical laws and codes. Failure to comply can create a back feed into utility lines creating an electrocution hazard, which may result in serious injury or death to utility workers. Such a back feed may cause this generator to explode, burn and create fires when utility power is restored.
- Use a ground fault circuit interrupter (GFCI) in highly conductive areas such as metal decking or steel work. GFCIs are available in-line with some extension cords.
- Do not use this generator in wet conditions (rain, snow, active sprinkler system, wet hands, etc.). Always keep this generator dry and operate it with dry hands.
- Do not touch bare wires or outlets (receptacles).
- Do not allow children or non-qualified persons to operate this generator.

⚠ DANGER

High Temperatures: This generator produces heat when in operation. Temperatures near the exhaust can exceed 150 Degrees Fahrenheit (65 Degrees Celsius).

- Do not touch hot surfaces. Observe all warning placards on this generator denoting hot surfaces.
- Allow this generator to cool for several minutes after use before touching the engine, muffler or other areas that are hot during operation and before storing indoors.
- Hot exhaust may ignite some materials. Keep flammable materials away from this generator.
- Keep at least several feet of clearance on all sides of this generator during operation. Do not enclose this generator in any structure.

⚠ CAUTION

Usage: Misuse of this generator can damage it or shorten its life.

- Use this generator only for its intended purpose.
- Operate this generator only on a dry, level surface. Do not secure the generator with a chain or rope, which would prevent it from being moved in an emergency.
- Allow this generator to run for several minutes before connecting any electrical devices.
- Promptly turn off any malfunctioning devices and disconnect them.
- Do not operate an excessive number of electrical devices in excess of the wattage capacity of this generator.
- Do not turn on electrical devices until *after* they are connected to this generator.
- Turn off all connected electrical devices before stopping this generator.

⚠ CAUTION

Usage: Prolonged exposure to high noise levels can be hazardous to hearing. Always wear ANSI-approved hearing protection when operating or working around the generator when it is running.

CAUTION

Usage: This generator is not intended to power sensitive electronic equipment such as TVs, DVD players, stereos, desktop computers or laptop computers without the use of an appropriate line conditioner and/or surge protector (both not included). Sensitive electronic equipment should be operated on approved inverter type generators or pure sine wave generators. For additional information consult the devices operation manual or contact your local authorized service center.

⚠ WARNING

Usage: Avoid the use of extension cords if possible. If you choose to use them, be sure they are sized adequately to handle the flow of electricity. An undersized cord can overheat, short out and cause a fire.

⚠ CAUTION

Usage: Do not use fuel stabilizers with this generator, doing so could cause damage to the generator, or decrease the fuel and operating efficiency of the generator. You may choose to add a fuel conditioner to oxygenate the fuel and to help it run more efficiently.

⚠ WARNING

USE THIS GENERATOR ONLY OUTDOORS IN NON-CONFINED AREAS. DO NOT SECURE THE GENERATOR WITH A CHAIN OR ROPE, AS THIS WILL MAKE IT DIFFICULT TO MOVE IN AN EMERGENCY.

 **WARNING**

The engine exhaust from this product contains chemicals known to the State of California to cause cancer, birth defects or other reproductive harm.

 **DANGER**

EXHAUST CONTAINS POISONOUS CARBON MONOXIDE GAS THAT CAN BUILD UP TO DANGEROUS LEVELS IN CLOSED AREAS. BREATHING CARBON MONOXIDE CAN CAUSE UNCONSCIOUSNESS OR DEATH. Never run the generator in a closed or even partly closed area where people may be present.

 **WARNING**

DIESEL IS HIGHLY FLAMMABLE AND EXPLOSIVE. YOU COULD BE BURNED OR SERIOUSLY INJURED IF THE GASOLINE IS IGNITED. Before refueling, stop the engine and keep heat, sparks and flame away. Handle fuel only outdoors. Do not fill the fuel tank above the upper limit line. Wipe up spills immediately.

 **WARNING**

IMPROPER CONNECTIONS TO A BUILDING CAN ALLOW ELECTRICAL CURRENT TO BACKFEED INTO UTILITY LINES, CREATING AN ELECTROCUTION HAZARD. Connections to a building must isolate generator power from utility power and comply with all applicable laws and electrical codes.

In addition to the previously described safety information, familiarize yourself with all safety and hazard placards on this generator.

⚠ DANGER POISONOUS GAS

Generator exhaust contains toxic carbon monoxide gas. Breathing exhaust can cause loss of consciousness and shortness of breath. NEVER operate generator in poorly ventilated areas.

⚠ WARNING

Risk of electric shock. Do not remove cover. No user serviceable parts inside. Refer servicing to qualified service personnel.

⚠ WARNING! RISK OF ELECTRIC SHOCK

This generator produces high voltage. Always ground properly before use. Do not connect to any building electrical system. Never use in rainy or wet conditions. Never touch bare wires or receptacles. Never allow children or non-qualified person to operate.

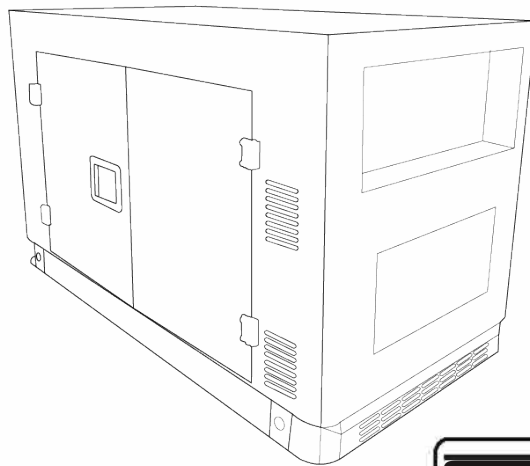
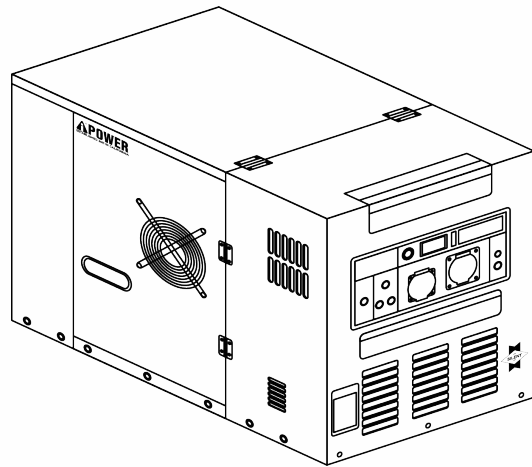
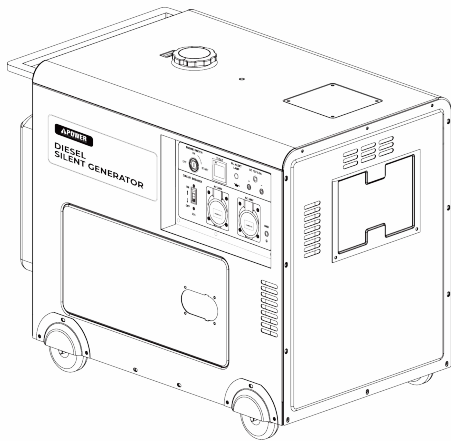

⚠ CAUTION! HOT EXHAUST

🚫 DO NOT TOUCH

⚠ 🚫 CAUTION! HIGH TEMPERATURE DO NOT TOUCH

⚠ DANGER

Using a generator indoors WILL KILL YOU IN MINUTES. Exhaust contains carbon monoxide, a poison gas you cannot see or smell.

<p>NEVER use in the home or in partly enclosed areas such as garages.</p>	<p>ONLY use outdoors and far from open windows, doors, and vents.</p>
---	---

⚠ WARNING

USE THIS GENERATOR ONLY OUTDOORS IN NON-CONFINED AREAS. DO NOT SECURE THE GENERATOR WITH A CHAIN OR ROPE, AS THIS WILL MAKE IT DIFFICULT TO MOVE IN AN EMERGENCY.

GENERATOR COMPONENTS

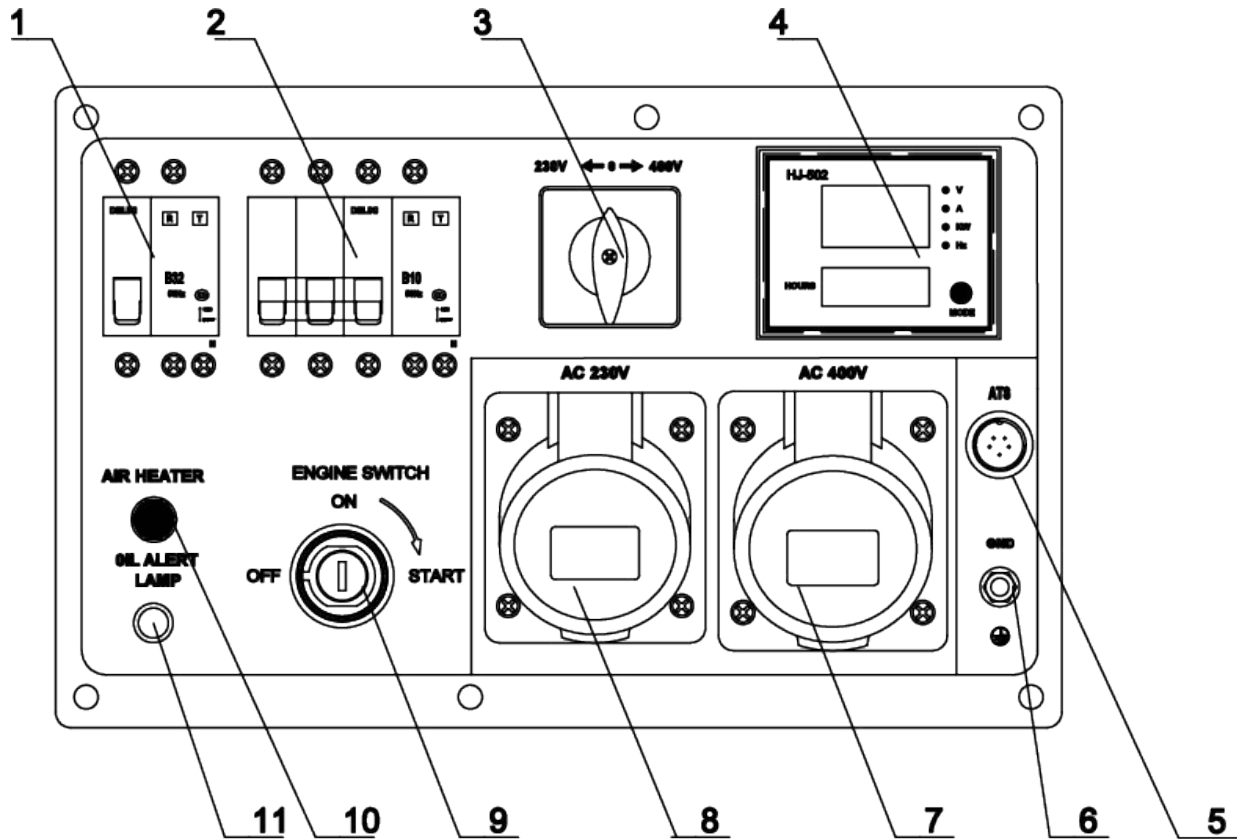

APD9500Q Control Panel

- 1) Air Switch 1-32A
- 2) Air Switch 3-10A
- 3) Voltage Transfer Switch
- 4) Display Table
- 5) ATS Connection
- 6) Ground Terminal

- 7) Schuko Socket 400V
- 8) Schuko Socket 230V
- 9) Electric Start Switch
- 10) Air Heater
- 11) Oil Alert Lamp

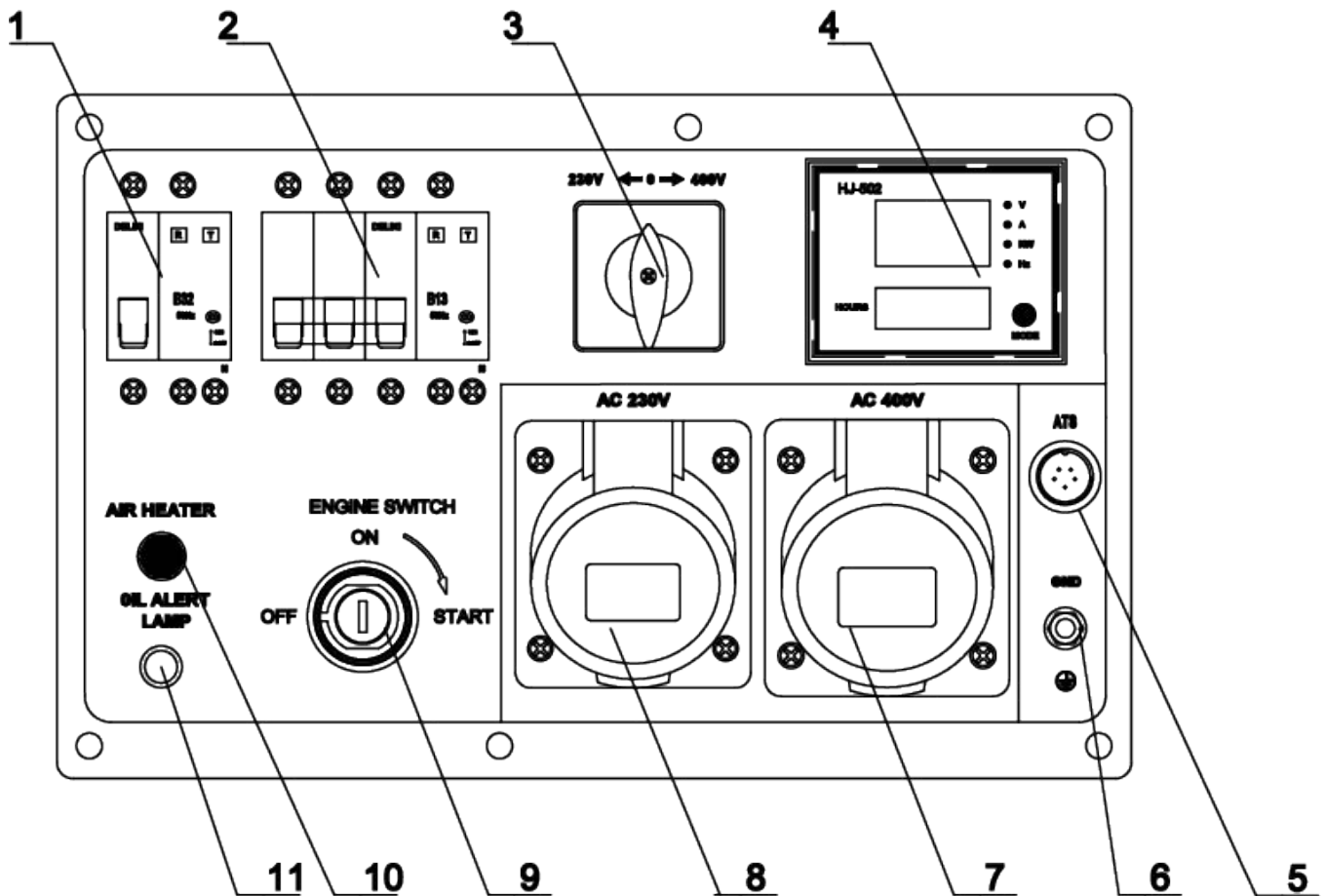

APD11000Q Control Panel

- | | |
|----------------------------|--------------------------|
| 1) Air Switch 1-32A | 7) Schuko Socket 400V |
| 2) Air Switch 3-13A | 8) Schuko Socket 230V |
| 3) Voltage Transfer Switch | 9) Electric Start Switch |
| 4) Display Table | 10) Air Heater |
| 5) ATS Connection | 11) Oil Alert Lamp |
| 6) Ground Terminal | |

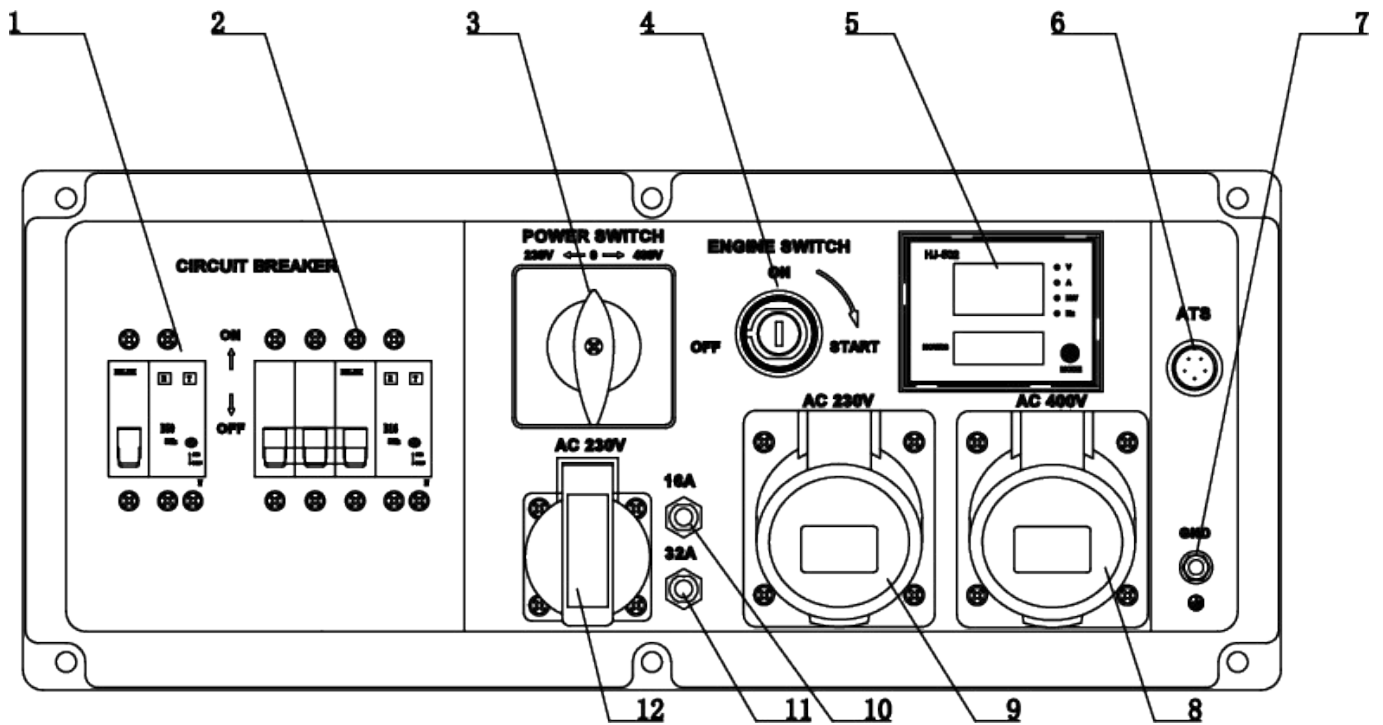

APD13000Q Control Panel

- | | |
|----------------------------|---------------------------|
| 1) Air Switch 1-32A | 7) Ground Terminal |
| 2) Air Switch 3-13A | 8) Schuko Socket 400V |
| 3) Voltage Transfer Switch | 9) Schuko Socket 32A230V |
| 4) Electric Start Switch | 10) Thermal Protector 16A |
| 5) Display Table | 11) Thermal Protector 32A |
| 6) ATS Connection | 12) Schuko Socket 16A230V |

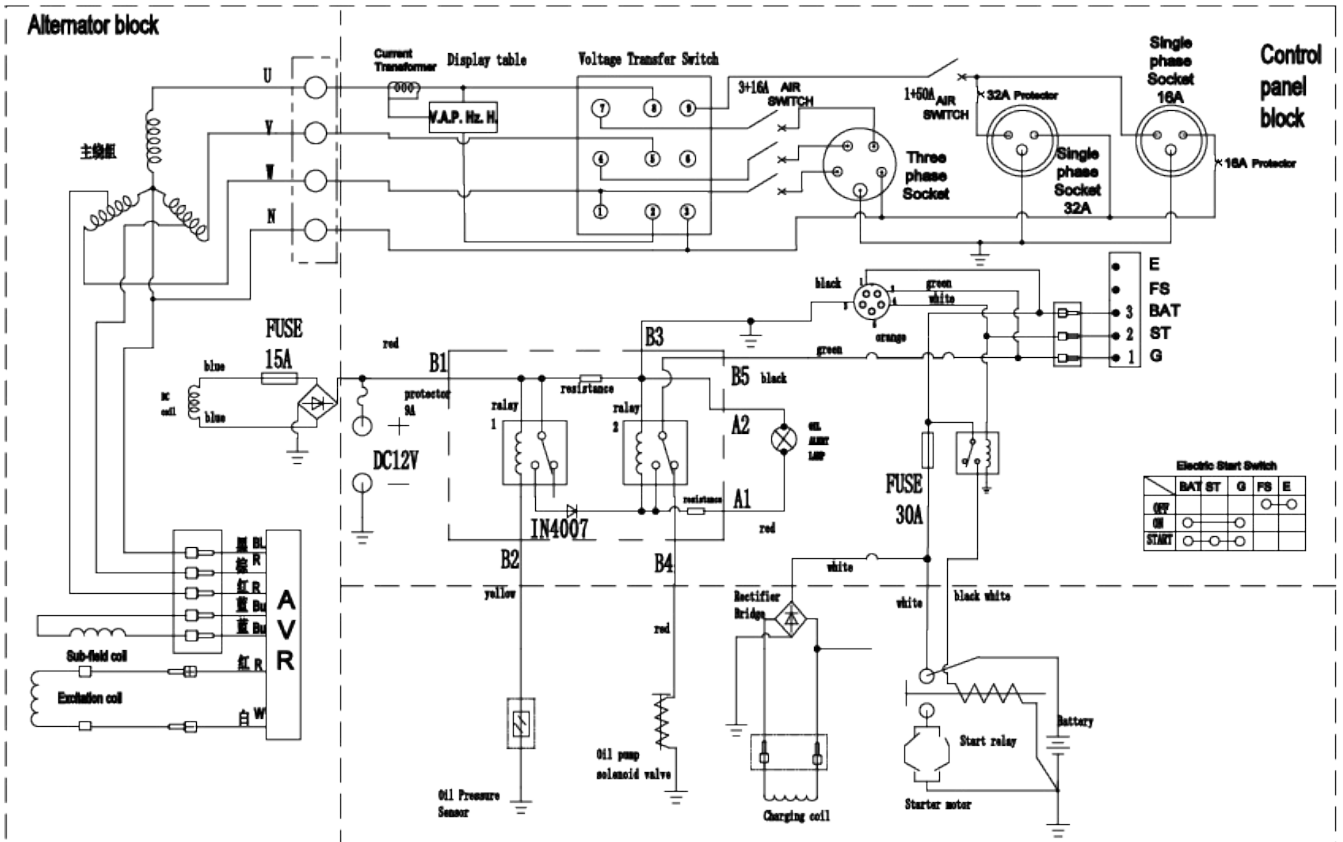

APD13000Q

The Circuit Principle Diagram

PREPARING THE GENERATOR FOR USE

STOP!

The following section describes the required steps for preparing this generator for use. Failure to correctly perform these steps can damage this generator and/or shorten its life.

If this generator is being used for the first time, the following few steps are required to prepare it for operation:

Step 1 - Add Oil, Then Add Diesel Fuel

This generator requires engine oil to function. Engine oil is a major factor affecting engine performance and service life. When new from the package, this generator contains no oil in the engine crankcase. The correct quantity of oil is equal to the oil capacity of the engine crankcase. Add the correct quantity of oil before operating this generator for the first time.

Oil Type Recommended	SAE 20W-40 Diesel Grade
----------------------	-------------------------

To add oil:

1. Confirm that this generator is on a level surface.
2. Open the Oil Access Panel as illustrated in Figure 1 and Figure 2.
3. Using a funnel, add high detergent motor oil to fill the engine crankcase to the correct quantity as stated above. SAE 20W-40 Diesel Grade oil is recommended. When the engine crankcase is full, the oil level should reach the lower lip of the oil fill opening.
4. Replace the oil filler/dipstick cap and close the oil access panel.

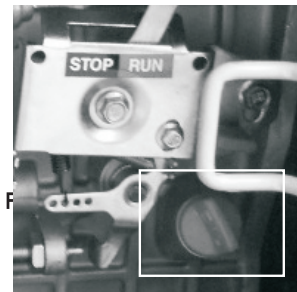
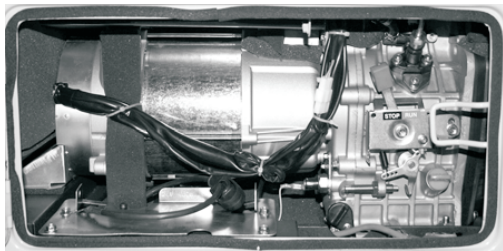

⚠ WARNING

Diesel Fuel and fumes are highly flammable and explosive. Handling fuel can result in serious injury or burns.

Do not fill the fuel tank near a heat, sparks or an open flame. Keep fuel away from appliance pilot lights, barbecues, electric appliances, power tools, etc. Do not overfill the fuel tank. Always check for fuel spills and immediately wipe them up. Spilled fuel is a fire hazard.

To add diesel fuel, use only FRESH, DIESEL FUEL:

1. Confirm that this generator is on a level surface.
2. Unscrew fuel tank cap and set aside. (NOTE: The fuel tank cap may be tight and difficult to unscrew.)
3. Slowly add fresh, diesel fuel to the fuel tank. Be careful not to fill the fuel tank above the upper limit line.

NOTE: Because diesel fuel can expand, do not fill the fuel tank to the very top.

4. Securely tighten the fuel tank cap and immediately wipe up any spilled fuel with a dry cloth.

Fuel Type	Diesel Fuel
-----------	-------------

Step 2 - Ground the Generator

⚠ WARNING

Failure to properly ground this generator can result in electrocution.

Ground this generator by tightening the grounding nut against a grounding wire (Figure 3), found on the front of the battery. A No. 12 AWG stranded copper wire is generally an acceptable grounding wire. The other end of this grounding wire should be connected to a copper or brass-grounding rod that is driven into the earth.

Grounding codes can vary by location. Contact a local electrician for information on grounding regulations for your area.



Step 3 – Install Battery (If not included)

This generator requires a battery to start. The generator does not come equipped from the factory with a battery.

A 12 Volt motorcycle battery no larger than 7 3/4" L x 5 1/4" H x 7 1/4" W, with a 300 Minimum CCA (Cold Cranking Amps). Comparable brands/models are Husky: GT-X or Interstate: SP-35. These are not the only brands compatible with this generator. Any brand with similar specs may be used. The battery may be smaller in size, and have a higher CCA. ****Brands/model numbers can change, this information is intended as a guide only, if your sparkplug needs to be replaced, please visit your local auto parts store for their recommendation.**

The battery case is located behind the metal plate under the electrical panel. Install the battery by using the two cables (one red and the other black) that were included in the packaging, or are attached to the generator.

Disconnect all electrical loads from this generator before changing the battery.

1. Attach the end of the red cable to the positive/red terminal on the battery.
2. Attach the end of the black cable to the negative/black terminal on the battery.
3. Bolt the battery to the battery plate.

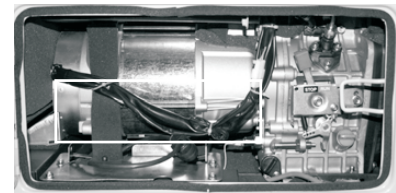

Step 3 Battery Location

STARTING THE GENERATOR

STOP!

Before starting this generator, confirm that all the steps in the section titled, "Preparing the Generator for Use," of this manual have been correctly completed. If unsure about how to perform any of these steps

If the generator has been used before, always check the oil level and diesel fuel level. Always check that the battery is secure and the generator has been grounded.

To start this generator:

1. Confirm that there are no electrical devices connected to this generator.
2. Confirm that this generator is properly grounded. (See "Ground the Generator")
Move Circuit breaker to ON position. (Figure 6A)
3. Set the engine Run switch to the "Run" position (Figure 6B).
4. Insert Key and turn it to the start position. (Figure 6C).
5. If the engine fails to start, repeat step 6. NOTE: After repeated attempts, consult the Troubleshooting Guide before attempting again. (You may need to open top panel and push down on Decompression Lever.)
6. Allow this generator to run for several minutes before connecting any electrical devices.

Choke Rod The choke is used to provide an enriched fuel mixture when starting a cold engine. It can be opened and closed by operating the choke rod manually. Pull the rod out toward CLOSED to enrich the mixture for cold starting.

Figure 6A

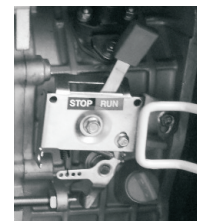

Figure 6B

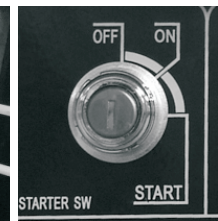

Figure 6C

USING THE GENERATOR

⚠ CAUTION

Connect only electrical devices that are in good working order. Faulty devices or power cords present the risk of electrical shock. Immediately turn off and disconnect any device that commences to operate abnormally, sluggish or abruptly stops. Determine if the problem was the device or the rated load capacity of this generator has been exceeded.

⚠ WARNING

- USE THIS GENERATOR ONLY OUTDOORS IN NON-CONFINED AREAS. DO NOT SECURE THE GENERATOR WITH A CHAIN OR ROPE, AS THIS WILL MAKE IT DIFFICULT TO MOVE IN AN EMERGENCY.
- KEEP AT LEAST SEVERAL FEET OF CLEARANCE ON ALL SIDES TO ALLOW PROPER VENTILATION FOR THIS GENERATOR.

After the engine has been running for several minutes, electrical devices may be connected to this generator.

AC Usage

Electrical devices running on AC current may be connected according to their wattage requirements. The rated (running) wattage corresponds to the maximum wattage a generator can output on a continuous basis.

The *surge wattage* corresponds to the maximum amount of power a generator can output for a short time. Many electrical devices, such as a refrigerator, require short bursts of extra power for starting and stopping fan motors, etc., in addition to their listed rated wattage. Motorized devices typically require more than their rated wattage for startup. The surge wattage ability of a generator allows for this extra power requirement.

The total running wattage requirement of the electrical devices connected to a generator should not exceed the rated wattage of the generator itself. To calculate the total wattage requirement of the electrical devices to be connected, look up the rated (running) wattage of each device and add these numbers together to find the total wattage that all of the devices together will draw from the generator. If the total wattage of the selected devices exceeds the rated wattage of the generator, DO NOT connect all of the devices. Select a combination of the electrical devices that will have a total wattage less than or equal to the rated wattage for the generator.

⚠ CAUTION

This generator can run at its surge wattage capacity for only a short time. Connect electrical devices requiring a rated (running) wattage equal to or less than the rated wattage of this generator. Never connect devices requiring a rated wattage equal to the surge wattage of a generator.

Electrical Device	Rated (Running) Watts	Additional Surge Watts
air compressor (1 - 1/2 HP)	2500	2500
airless sprayer (1/3 HP)	600	1200
coffee maker	1500	0
computer w/17 inch monitor	800	0
deep freezer	500	500
electric drill (1/2 HP)	1000	1000
furnace fan blower (1/2 HP)	800	1300
hot plate	2500	0
microwave oven (1000 watt)	1000	0
quartz halogen work light	1000	0
refrigerator/freezer (18 Cu. Ft.)	800	1600
saw - circular (7 1/4 inch)	1500	1500
stereo receiver	450	0
electric stove - single element	1500	0
sump pump	800	1200
television (27 inch color)	500	0
well water pump (1/3 HP)	1000	2000
window air conditioner (10000 BTU)	1200	1800
window fan	300	600

A device's rated (running) wattage should be listed somewhere on the device itself and/or in its manual. If the wattage specification for a device is not available, the wattage can be calculated by multiplying the Voltage requirement (230 or 400) by the Amperage drawn.

Or, the wattage required by a device can be estimated by using the following chart. The chart provides only estimates and it is better to know the exact wattage of each electrical device to be powered by this generator.

$$\text{Watts} = \text{Volts} \times \text{Amperes}$$

Connect electrical devices to this generator according to the following procedure:

Allow the engine to run for several minutes after it has been started.

Confirm that the electrical device is switched off prior to plugging it into this generator.

NOTE: Plug appliances into the correct outlet. Connect standard 230 Volt, single phase, 50 Hz loads to the 230 Volt outlet. Connect 12 Volt, DC loads to the 12 Volt outlet.

Turn on the connected electrical devices beginning with the device with the highest rated wattage requirement and then each additional device with the next lower rated wattage requirement.

⚠ CAUTION

Do not connect 60Hz to this generator.

DC Usage

⚠ CAUTION

The DC terminal is only for recharging 12 Volt automotive-type batteries. Do not connect any other device to this outlet.

⚠ CAUTION

Use this generator only for recharging 12 Volt batteries. NEVER attempt to jumpstart a car with this generator.

⚠ DANGER

Failing to use the correct procedure can cause a battery to explode, seriously injuring anyone nearby. Keep heat, sparks, flame and smoking materials away from the battery.

To connect 12 Volt batteries to the DC outlet:

1. Connect one charging wire to the positive terminal of the battery and the other charging wire to the negative terminal of the battery.
2. Connect the free end of the positive wire to the positive side of the outlet on this generator.
3. Carefully connect the free end of the negative wire to the negative side of the outlet on this generator.
4. Start this generator.
5. When disconnecting, always disconnect the wires from this generator first to avoid a spark.

⚠ DANGER

Storage batteries emit highly explosive hydrogen gas when charged.

Batteries also contain acid, which can cause severe chemical burns.

- Do not allow open flames or cigarettes nearby for several minutes after charging a battery.
- Always wear protective goggles and rubber gloves when charging a battery.
 - If battery acid gets on the skin, flush with water.
 - If battery acid gets in the eyes, flush with water and immediately call a physician.
 - If battery acid is swallowed, drink large quantities of milk and immediately call a physician.

⚠ DANGER

Do not secure the generator with a chain or rope, which would prevent it from being moved in an emergency.

STOPPING THE GENERATOR

To stop this generator:

1. Turn off all connected electrical devices and then unplug them.
2. Switch the circuit breaker to the "OFF" position. (Figure 10)
3. Allow this generator to run for several more minutes with no electrical devices connected to help stabilize the temperature of this generator.
4. Set the engine Run lever to the "Stop" position. (Figure 11)
5. Turn the Starter switch to Off Position. (Figure 12).



Figure 10



Figure 11



Figure 12

⚠ WARNING

Allow this generator to cool down before touching areas that become hot during operation.

⚠ CAUTION

Allowing diesel fuel to sit in this generator's fuel tank for extended time without use can increase the difficulty in starting this generator in the future. Never store this generator for extended time with fuel in the fuel tank.

MAINTENANCE/CARE

Proper routine maintenance of this generator is essential for safe, economical, and trouble-free operation. It will help prolong the life of this generator as well as help reduce air pollution. Perform maintenance checks and procedures according to the schedule in Figure 7.

⚠ CAUTION

Never perform maintenance procedures while this generator is running. Allow this generator to cool before commencing any maintenance procedures. Keep heat, sparks and flame away.

⚠ WARNING

Improper maintenance and/or failure to correct any problems prior to operating this generator can cause a malfunction which could cause death or serious injury. Always follow the inspection and maintenance recommendations and schedules in this manual.

Recommended Maintenance Schedule

		Each Use	Every Month or Each 20 Hrs	Every 3 Months or Each 50 Hrs	Every 6 Months or Each 100 Hrs	Every Year or Each 300 Hrs
Engine Oil	Check Level	X				
	Replace		X (First Use)		X	
Air Filter	Check	X				
	Clean			X		
Fuel Filler Cap	Clean				X	
Fuel Tank	Verify Gas Level	X				
	Clean					X

Figure 7 - Recommended maintenance schedule

Cleaning the Generator

Always try to use this generator in a cool dry place. If this generator becomes dirty, the exterior can be cleaned with a damp cloth, soft brush, vacuum and/or pressurized air.

Never clean this generator with a bucket of water and/or a hose as water can get inside and cause a short circuit or corrosion.

Never use gasoline to clean parts of this generator.

Checking the Oil Level

It is important to check the oil level in the engine crankcase before each use to ensure that there is a sufficient quantity.

To check the oil level:

1. Verify that this generator is shut down and on a level surface.
2. Unscrew the oil filler/dipstick cap from the engine.
3. With a dry cloth, wipe the oil off of the dipstick that is located on the inside of the cap.
4. Insert the dipstick as if replacing the cap and then remove again. There should be oil on the dipstick. If there is no oil on the dipstick, or oil is visible only at the very end of the dipstick, add oil until the engine crankcase is filled.
5. Confirm that the oil filler/dipstick cap is properly in place when finished verifying the oil level.

Changing/Adding Oil

The oil level in this generator should be checked before each use. (See Figure 8.) When the oil level is low, add oil until the level is sufficient to operate this generator.

To drain the oil from this generator:

The oil should be changed after the first 20 hours of operation. The oil should then be changed every 6 months, or for every 100 hours of use time, or when it has become contaminated with water and/or dirt.

1. Place a tray underneath this generator to catch oil as it drains.
2. Unscrew the oil drain plug located on the crankcase underneath the oil filler/dipstick cap.
3. Allow all the oil to drain from this generator.
4. Replace the oil drain plug and tighten.

NOTE: Never dispose of used motor oil in the trash, down a drain or on the ground. Put oil in a sealed container and contact your local recycling center or auto garage to arrange oil disposal.

To add oil to the engine crankcase:

1. Confirm that this generator is on a level surface.
2. Unscrew the oil filler/dipstick cap from the engine as illustrated in Figure 8 below.
3. Using a funnel, add high detergent motor oil to fill the engine crankcase to the correct quantity. SAE15W-40 Diesel Grade oil is recommended for general use. When the engine crankcase is full, the oil level should reach the lower lip of the oil filling opening.

Oil Type Recommended	SAE 20W-40 Diesel Grade
----------------------	-------------------------

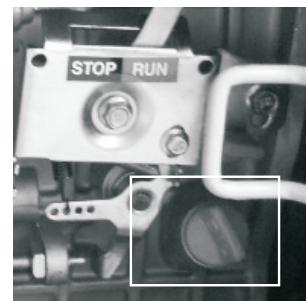
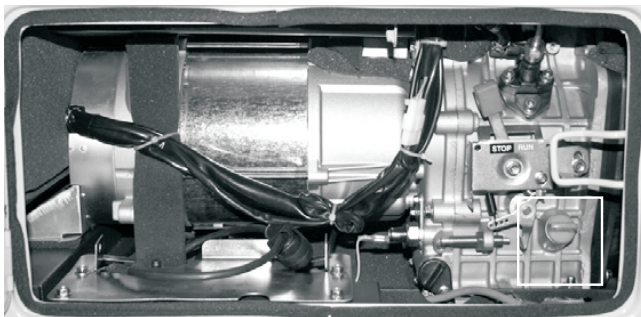

Figure 8

Air Filter Maintenance (Fuel Filter Maintenance)

Routine maintenance of the air filter helps maintain proper airflow to the carburetor. Occasionally verify that the air filter is free of excessive dirt. The air filter will require more frequent cleaning when operating this generator in extremely dusty areas.

To clean air filter, remove the access panel from side of generator, then remove wing nut to expose the element. (Figure 9)

Remove the foam filter element from the generator and wash it in warm water and household dish detergent. Thoroughly rinse and dry. Pour a small amount of motor oil onto the filter, ring out ALL excess oil, and reinstall the foam filter element in the generator.



Figure 9 – Changing The Air Filter



(Figure A – Change Fuel Filter located inside front access panel once a year)

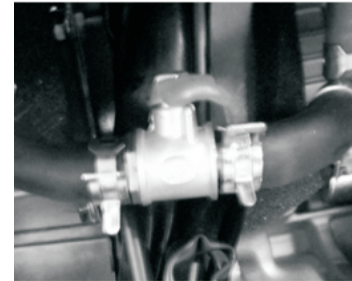

(Figure B – Fuel Valve)

Emptying the Fuel Tank

To store this generator for extended time, drain the diesel fuel from the fuel tank. To drain fuel from this generator:

1. Turn the fuel valve to the “off” position.
2. Remove the inline fuel filter.
3. Place a funnel underneath the fuel valve to catch fuel as it drains into a bucket.
4. Turn the fuel valve to the “on” position and allow all fuel to drain. (Figure B)
5. Turn the fuel valve to the “off” position.
6. Replace the inline fuel filter.
7. Store the drained fuel in a suitable place.

To store this generator for extended time, the fuel needs to be drained from the carburetor.

To drain the gasoline from the carburetor turn the fuel valve to the “off” position while the engine is running. The generator will shut down when all the gasoline in the carburetor has been used.

STORAGE/TRANSPORT PROCEDURES

CAUTION

Never place any type of storage cover on this generator while it is still hot.

When transporting or storing this generator for extended time:

- Allow generator to fully cool before moving it. A hot engine and exhaust system can burn you and ignite some materials.
- Empty the fuel tank. (See “Emptying the Fuel Tank” in the “Maintenance/Care” section.)
- Turn the fuel valve to the “off” position.
- Do not obstruct any ventilation openings.
- Do not drop or strike this generator while moving it.
- Store this generator in a cool dry area, free of excessive dust.

Storage Time	Recommended Storage Procedure (which will help prevent difficult starts)
Less than 1 month	No storage procedure required.
1 to 2 months	Fill with fresh diesel fuel
2 months to 1 year	Empty the fuel tank. (See “Emptying the Fuel Tank” in the “Maintenance/Care” section.)
1 year or more	Empty the fuel tank. (See “Emptying the Fuel Tank” in the “Maintenance/Care” section.)

Replacing The Carbon Brushes



1. Remove Muffer Access Panel



2. Remove Dual Muffer System



3. Remove Both Muffers



4. Remove End Panel



5. Brush Assembly is Visible



6. Locate Carbon Brushes

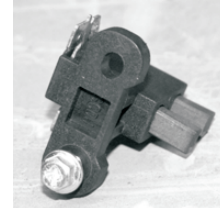

7. Replace Carbon Brushes

TROUBLESHOOTING

IMPORTANT: If trouble persists, please contact the retailer.

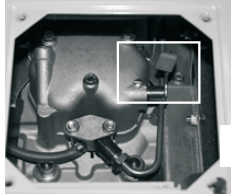
Symptom	Cause	Solution
Engine will not start.  (Figure 8)	Engine switch is set to "off."	Set engine switch to "on."
	Engine is out of diesel fuel.	Add diesel fuel.
	Oil is low.	Add or replace oil.
	Generator is not on level surface.	Move generator to a level surface to prevent triggering the low oil shutdown.
	Spring loaded Decompression Lever has closed the exhaust valve.	Open top panel. (Figure 8) Push down on Decompression Lever, reinstall top panel. Start engine.
	Engine is filled with contaminated and/or old diesel fuel.	Drain fuel from the engine and add new diesel fuel.
Engine runs but there is no electrical output.	Circuit breaker is off.	Flip circuit breaker to "on."
	Reset button is "off."	Push reset button to "on."
	Bad connecting wires/cables.	Try a different extension cord.
	Bad electrical device connected to generator.	Disconnect device, try connecting another device.
	Loose wiring and/or connection behind control panel or at end of generator.	Tighten the nuts that secure the wiring.
Carbon brushes or AVR are worn or broken.	See Figure B . Visually inspect to make sure they are in contact with the two copper bands on the rotor. Replace as necessary.	
Generator runs but does not support all connected electrical devices.	Generator is overloaded.	Reduce draw on generator to within this generator's rated wattage by reducing number of connected electrical devices.
	Short in one of the connected devices.	Disconnect any faulty or short-circuited electrical loads.
	Air filter is dirty.	Clean or replace air filter.

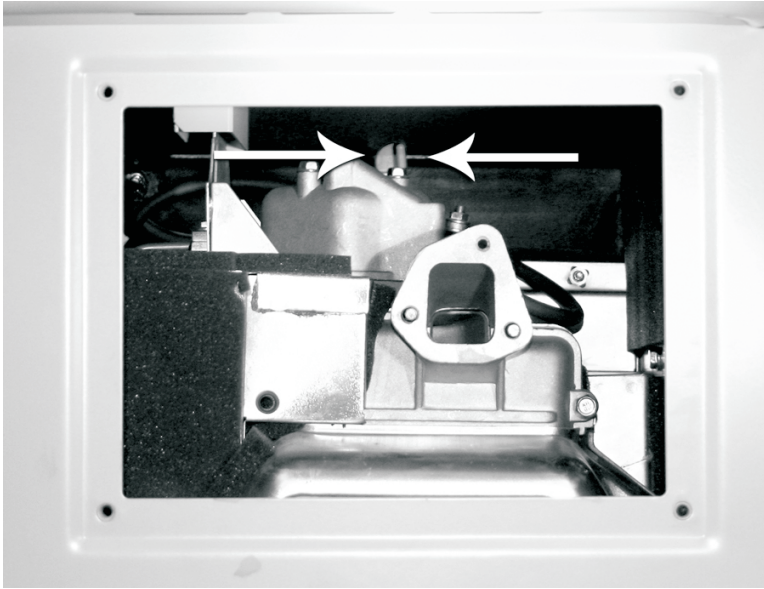

Figure A – Remove side panel, then remove air filter. Locate the “Red” Decompression Lever (Photo above shows it in the UP position). Press the lever down – this will hold the exhaust valve open. Replace the air filter assembly. Start the engine. You will notice that the spring loaded lever will automatically return to the UP position. (Also referred to as the decompression shaft assembly on the parts diagram.)

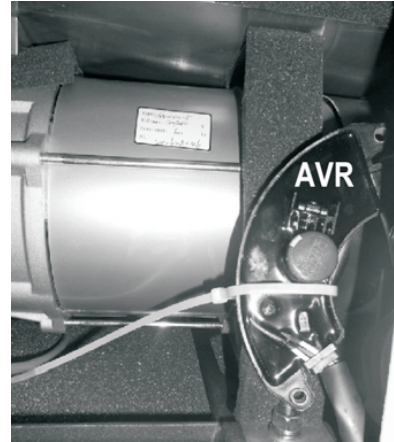

Figure B - Review the location of the AVR (Automatic Voltage Regulator. This item may eventually need to be replaced when they wear out.

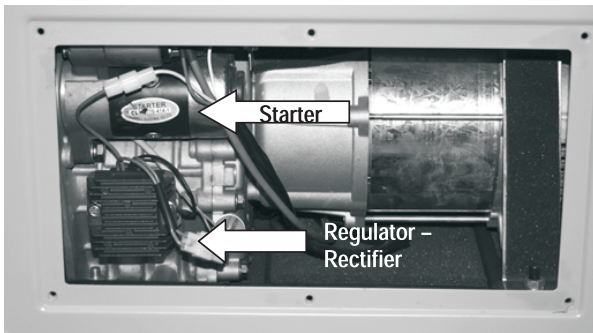

Figure C - Review the location of the rear access panel that has been removed. You can see the location of the starter and the regulator/rectifier for the 12V starting battery. The starter motor is located above the regulator/rectifier.

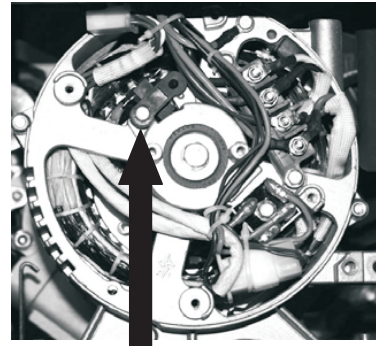
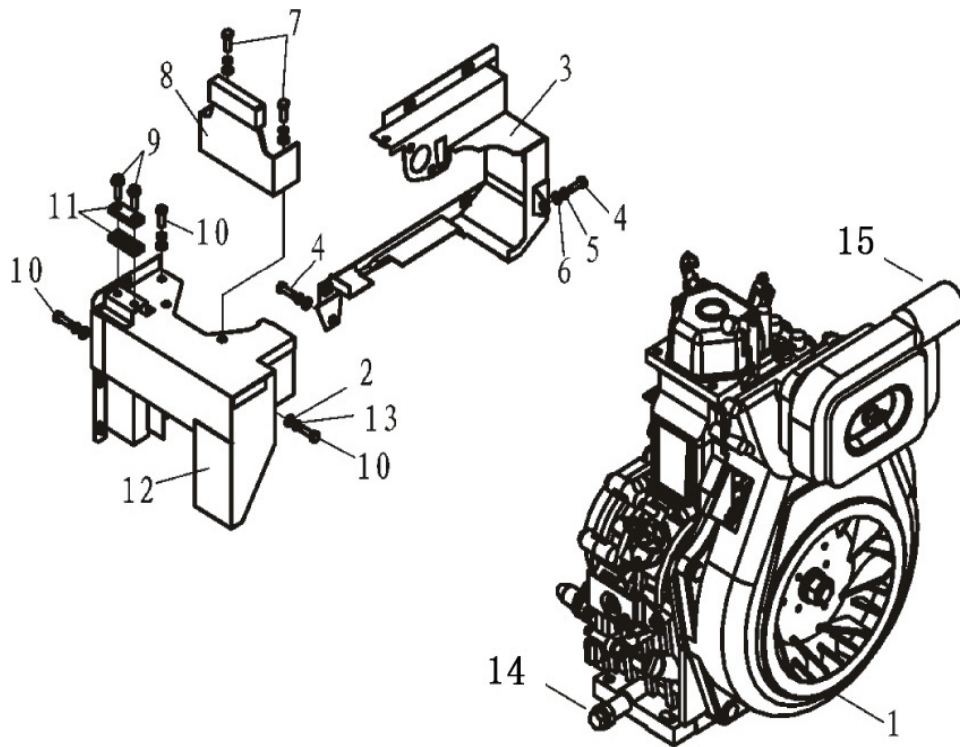
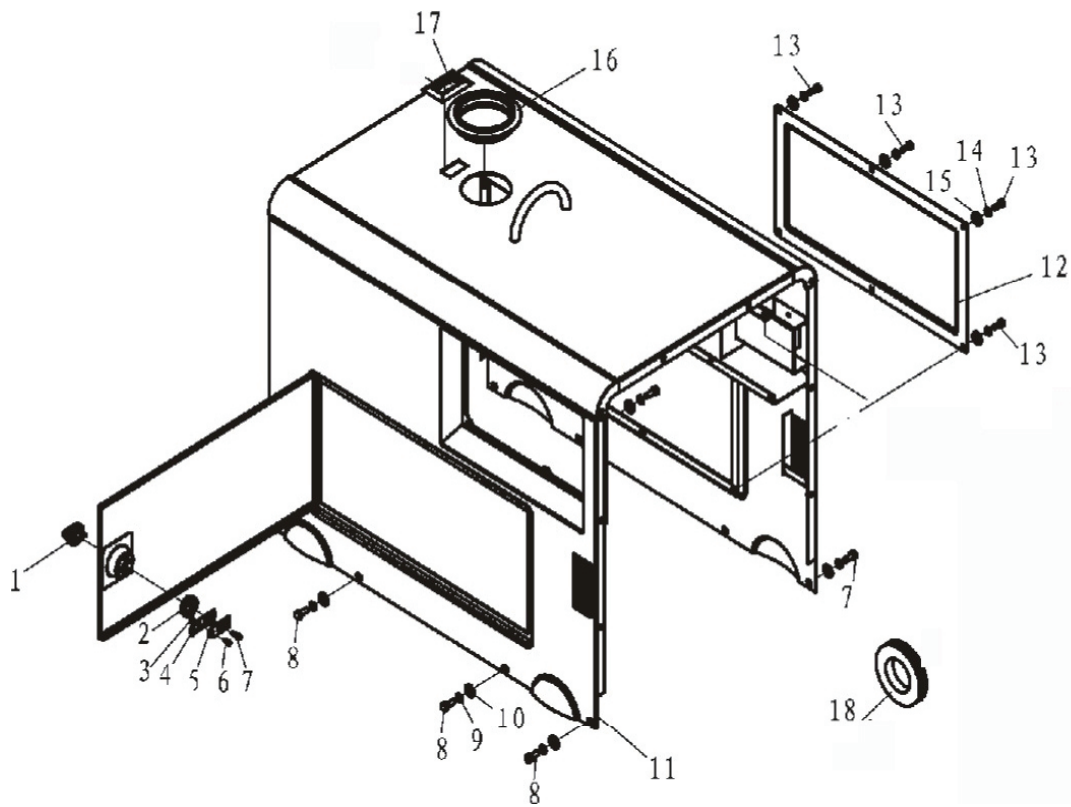

Figure D - Review the location of the Carbon Brushes. This item may eventually need to be replaced when they wear out.

Exploded view



No.	Part Number	Part Description	Qty
1	186FA 188FA 192F	Air Cooled Diesel Engine	1
2	GB/T97.1-2000	Gasket 6	2
3	6700-01001	Front Air Guide Plate 6700.7500	1
	8500-01001	Front Air Guide Plate 85000	1
4	GB/T5783-2000	Bolt M8x16	2
5	GB/T93-1987	Elastic Washer 8	2
6	GB/T97.1-2000	Flat Gasket 8	2
7	GB/T5783-2000	Bolt M8x16	2
8	6700-01002	Buffer Bracket Unit 6700,7500	1
	8500-01002	Buffer Bracket Unit 8500	1
9	GB/T5783-2000	Bolt M6X30	2
10	GB/T5783-2000	Bolt M6X20	2
11	6700-01003	Fuel Pipe Pressure Plate Unit	1
12	6700-01004	Rear Air Guide Plate Weldment 6700,7500	1
	8500-01004	Rear Air Guide Plate Weldment 8500	1
13	GB/T93-1987	Elastic Washer 6	2
14	6700-01005	Oil Drain Bolt (Longer)	1
15	186F-07000B	Air Filter Assembly (Silent Diesel generator)	1
	186F-07100	Air Filter Element 186. 188	1
	192F-07100	Air Filter Element 192	1



No.	Part Number	Part Description	Qty
1	6700-05100	Door Lock Assembly	1
2			1
3			1
4			1
5			1
6			1
7			1
8	GB/T5783-2000	Bolt.M620	8
9	GB/T93-1987	ElasticWasher 6	8
10	GB/T96.2-2002	BigGasket 6	8
11	6700-05200	CasingWeldment	1
12	6700-01001	RearPlateWeldment	1
13	GB/T5783-2000	Bolt.M616	6
14	GB/T93-1987	ElasticWasher 6	6
15	GB/T96.2-2002	BigGasket 6	6
16	6700-05002	Damping Cushion of the FuelTank	1
17	6700-05003	BuoyWindow	1
18	6700-05004	Window Mount Sheath	1

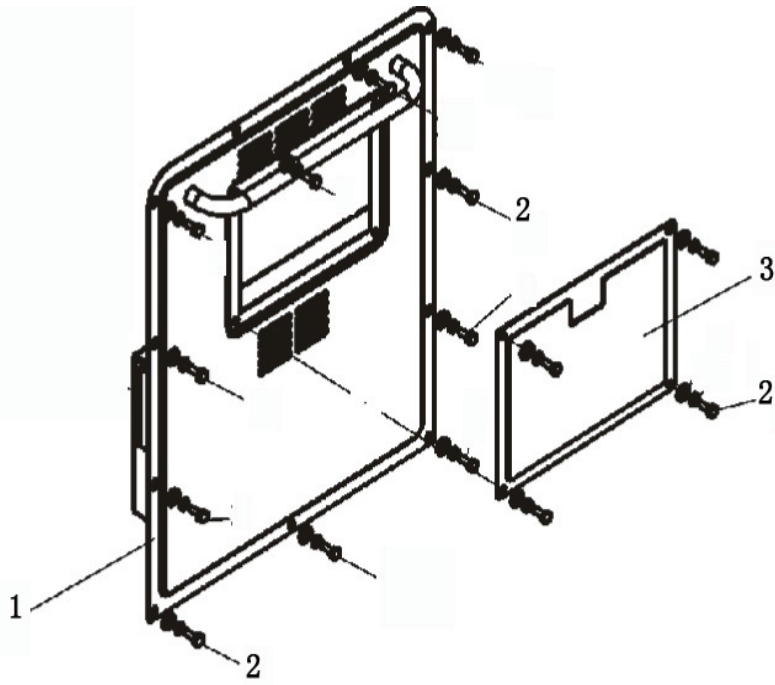

No.	Part Number	Part Description	Qty
1	KDF6700-06100	RightSidePlateWeldment	1
2	GB/T5783-2000	Bolt.M6x16	15
3	6700-06001	Air Cleaner CoverPlate	1

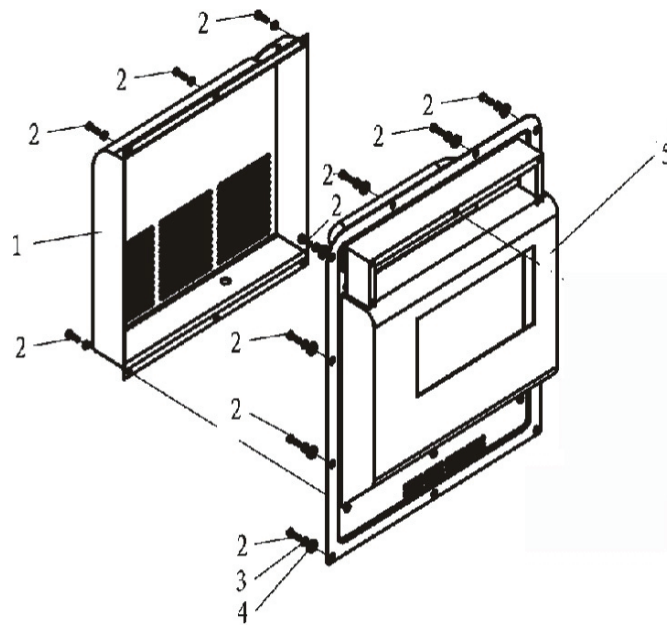

No.	Part Number	Part Description	Qty
1	6700-04100	RadiatingPlate	1
2	GB/T5783-2000	Bolt.M6x16	17
3	GB/T93-1987	ElasticWasher 6	17
4	GB/T96-1985	BigGasket 6	11
5	6700-04200	LeftSidePlateWeldment	1

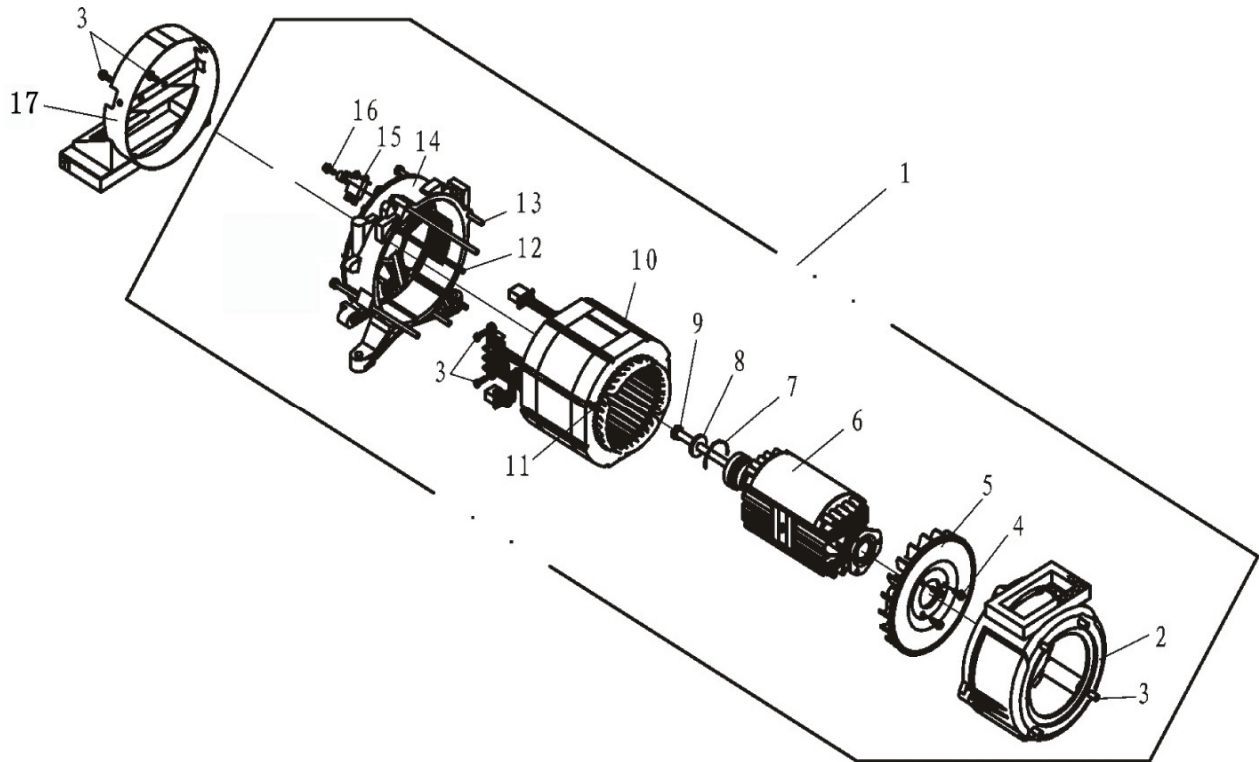

No.	Part Number	Part Description	Qty
1	6700Q-02000	6700 Alternator Assembly,Single Phase	1
	7500Q-02000	7500 Alternator Assembly,Single Phase	1
	8500Q-02000	8500 Alternator Assembly,Single Phase	1
	6700Q-3-02001	6700 Alternator Assembly,Three Phase 380T	1
	7500Q-3-02001	7500 Alternator Assembly,Three Phase 380T	1
	8500Q-3-02001	8500 Alternator Assembly,Three Phase 380T	1
	6700Q-3-02002	6700 Alternator Assembly,Three Phase 220T	1
	7500Q-3-02002	7500 Alternator Assembly,Three Phase 220T	1
	8500Q-3-02002	8500 Alternator Assembly,Three Phase 220T	1
2	6700-02001	Front Cover ofMotor	1
3	GB/T5783-2000	BoltM8x30	4
4	GB/5786-2000	ScrewM5x12	7
5	6700-02002	MotorFan	1
6	6700-02100	Rotator 6700,Single Phase	1
	7500-02100	Rotator 7500,Single Phase	1
	8500-02100	Rotator 8500,Single Phase	1
7	6204DU	Clip	1
8	6700-02003	Gasket	1
9	6700-02004	Bolt (LockingRot or)	1
10	6700-02200	Stator 6700,single Phase	1
	7500-02200	Stator 7500,single Phase	1
	8500-02200	Stator 8500,single Phase	1
	6700-3-02201	Stator 6700,Three Phase 220/380V	1
	7500-3-02201	Stator 7500,Three Phase 220/380V	1
	8500-3-02201	Stator 8500,Three Phase 220/380V	1
	6700-3-02202	Stator 6700,Three Phase 127/220V	1
	7500-3-02202	Stator 7500,Three Phase 127/220V	1
8500-3-02202	Stator 8500,Three Phase 127/220V	1	
11	GB/810-1988	Round NutM5	2
12	GB/T5783-2000	BoltM 5(Locking Stator)	2
13	GB/T5783-2000	BoltM 6(Locking front Cover)	4
14	6700-02002	Rear Cover of Alternator	1
15	D104	Carbon Brush	1
16	GB/5786-2000	ScrewM5x14	2
17	6700-02100	AirGuide Cover ofMotorWeldm ent	1
	8500-02100	AirGuide Cover ofMotorWeldm ent	1

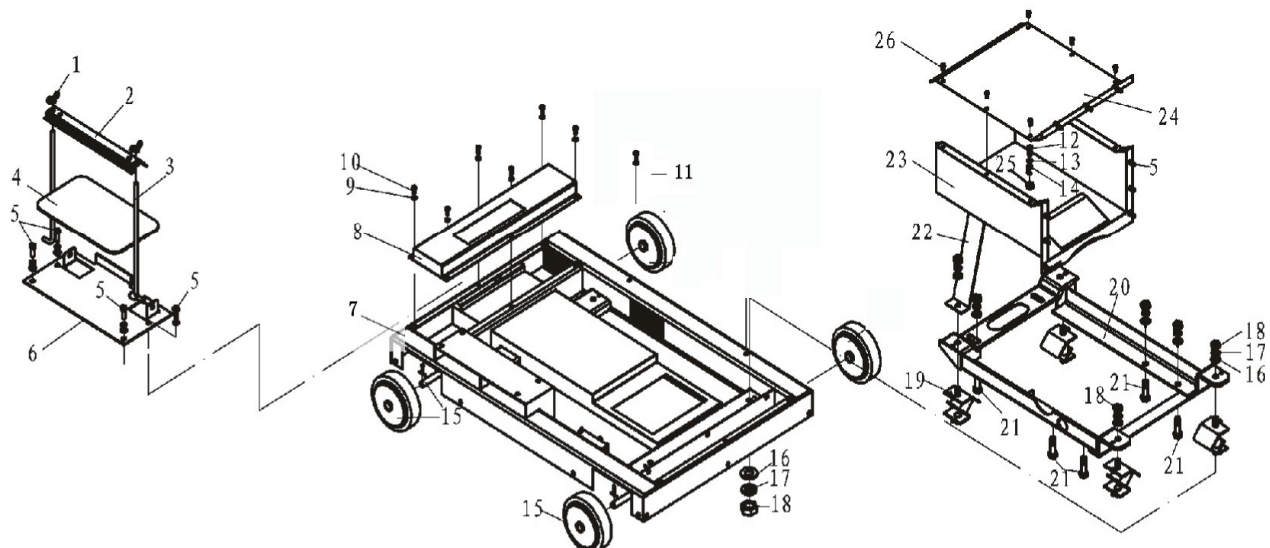

No.	Part Number	Part Description	Qty
1	GB/62-1988	Nut M6	2
2	6700-08002	PressurePlate of Battery 6	1
3	6700-08001	Fastenrod of Battery	2
4	6700-08004	BasePlate of Battery	1
5	GB/T5783-2000	Bolt M6x20	13
6	6700-03001	SupportPlate of Battery	1
7	6700-03200	ChassisWeldment	1
8	6700-03002	TailstockAir Hole of Motor	1
9	GB/T93-1987	ElasticWasher 5	6
10	GB/T5783-2000	Bolt M5x12	6
11	GB/T5789-2000	Bolt M6x12	1
12	GB/T5783-2000	Bolt M6x20	4
13	GB/T93-1987	ElasticWash	4
14	GB/T97.1-2002	FlatGasket 6	4
15	6700-03004	Castor	2
16	GB/T97.1-2002	FlatGasket 10	14
17	GB/T93-1987	ElasticWashers 10	14
18	GB/T6170-2000	Nut M10	14
19	6700-07000	DampingBlock	4
20	6700-03100	Weldment of Frame Base seat 6700,7500	1
	8500-03100	Weldment of Frame Base seat,8500	1
21	GB/T5783-2000	Bolt M10x45	6
22	6700-03005	Bracket of Heat Insulation Box Weldment	1
23	6700-03006	Lower Body of Heat Insulation Box Weldment	1
24	6700-03007	Cover Plate of Heat Insulation Box	1
25	GB/T6170-2000	Nut M6	2
26	GB/T818-2000	Bolt Screw M6x12	6

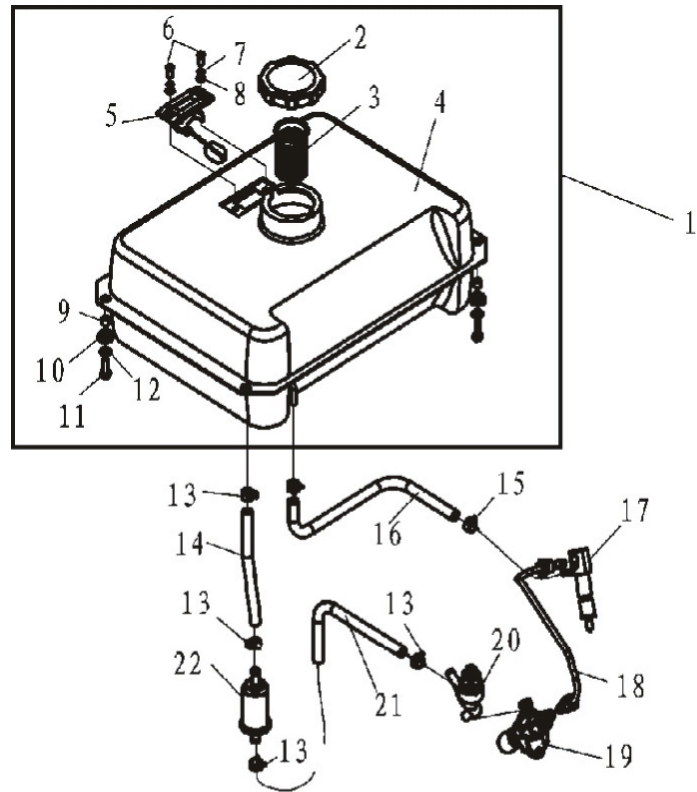

No.	Part Number	Part Description	Qty
1	6700-07000	FuelTank	1
2	6700-07200	FuelTank Cover	1
3	6700-07001	FilterScreen ofF illing	1
4	6700-07100	FuelTankWeldment	1
5	6700-07300	Oil Indicator	1
6	GB/T818-2000	Screw.M5x12	2
7	GB/T93-1987	ElasticWasher 5	2
8	GB/T97.1-2000	FlatGasket 5	2
9	6700-07002	Sheath	4
10	6700-07003	DampingSheath	4
11	GB/T5783-2000	Bolt.M6x30	4
12	GB/T97.1-2000	FlatGasket 6	4
13	13 Clip	Clip I	4
14	KDF6700-07004	Fuel DeliveryPipe I	1
15	9 Clip	Clip II	2
16	6700-07005	Oil ReturnPipe	1
17	186FA-12000	Nozzle 6700,7500,8500	1
18	186FA-10500A	HighPressureFuelPipe	1
19	186FA-13000	Fuel InjectionPump Unit6700,7500,8500	1
20	186FA-13000A	Fuel ControlValve Unit	1
21	6700-07006	Fuel DeliveryPipe II	1
22	6700-07400	FuelFilter	1

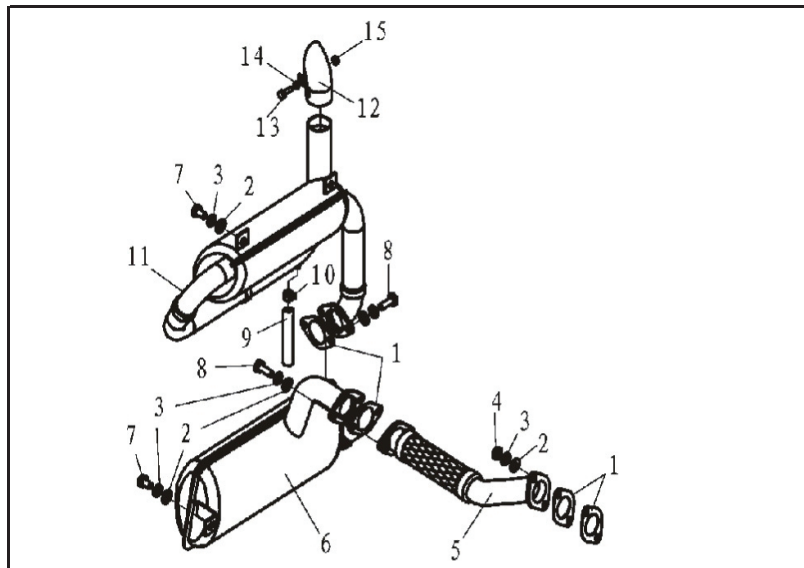

1	K	Exhaust Pipe Washer6700 、 7500	4
	192F-02015	Exhaust Pipe Washer8500	4
2	GB/T97.1-2000	Flat Gasket 8	9
3	GB/T93-1987	Elastic Washer8	9
4	GB/T6170-2000	Nut M8	2
5	6700-08100	Exhaust Pipe Unit6700 、 7500	1
	8500-08100	Exhaust Pipe Unit8500	1
6	6700-08200	Silent GeneratorMuf fler Assembly	1
11	6700-08300		1
7	GB/T5783-2000	Bolt.M8x16	3
8	GB/T5783-2000	Bolt.M8x30	4
9	6700-08001	Outlet Tube of Tail Air Particle	1
10	φ13 Clip	Clip I	1
12	6700-08400	Return Outlet of Tail Air Weldment	1
13	GB/T5783-2000	Bolt.M630	1
14	GB/T97.1-2000	Flat Gasket 6	1
15	GB/T6170-2000	Nut M6	1

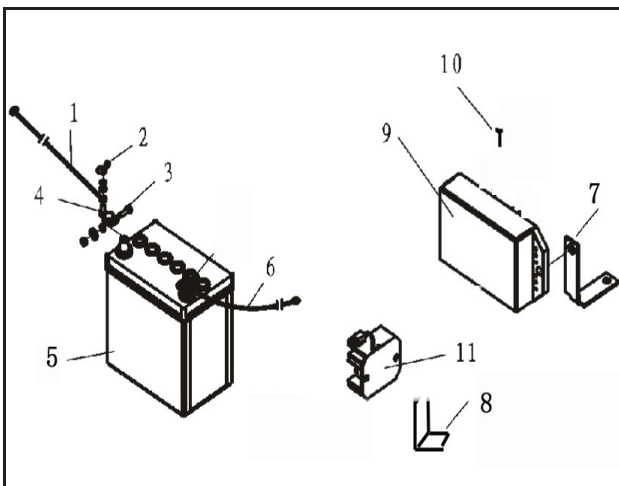

1	6700-10001	Battery Positive Wiring (Red)	1
2	GB/62-1988	Wing Nut M6	2
3	GB/T5783-2000	Bolt M6X25	2
4	6700-10002	Battery Positive Wiring Clip	1
5	12V 36Ah	12V36AH Battery	1
6	6700-10003	Battery Ground Wire (Black)	1
7	6700-10004	AVR Bracket	1
8	6700-10005	Bracket ofRegulator	1
	6700-10006	6700,7500,8500 AVR(Single Phase)	1
	6700-3-10006	6700,7500,8500AVR(Three Phase)	1
	6700-3D-10006	6700,7500,8500 3D AVR	6
10	GB/T5789-2000	Bolt M6X20	1
11	186F-12100	Charging Adjustor	1

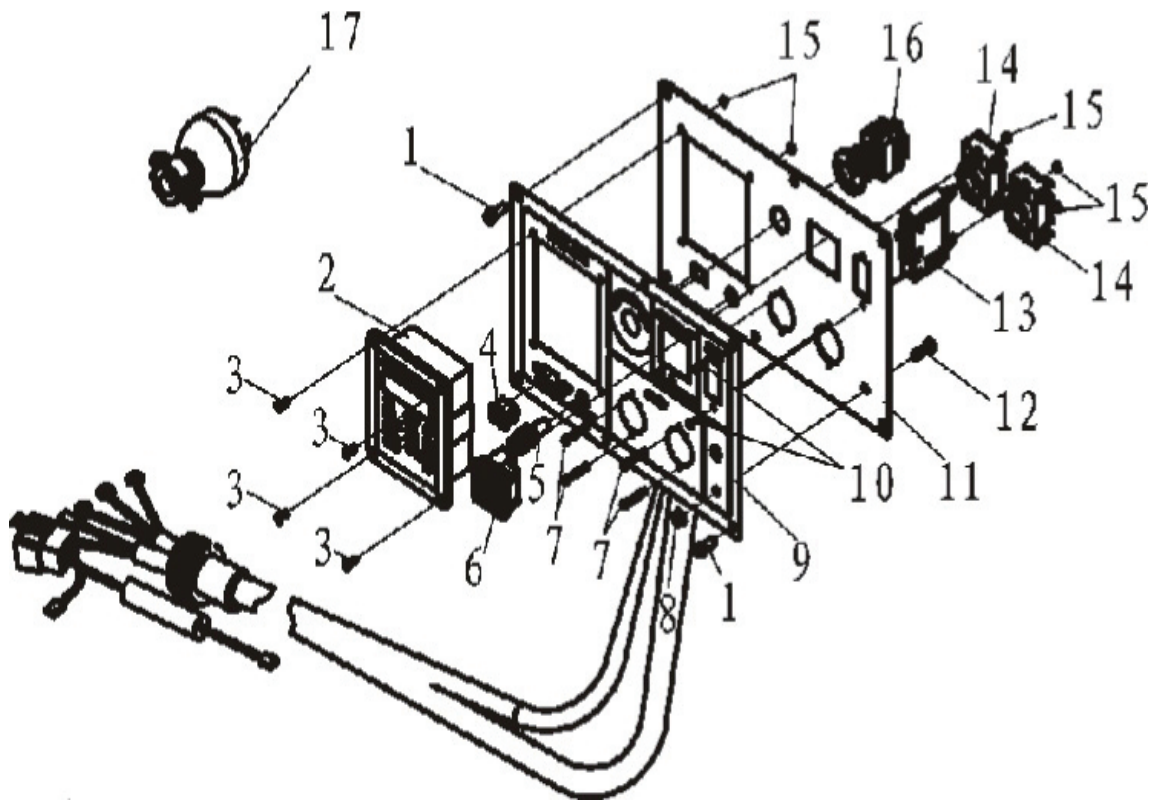

No.	Part Number	Part Description	Qty
1	GB/T818-2000	Screw M6x12	6
2	CP001	Digital ControlPanel	1
3	GB/T819.1-2000	Screw M4x12	4
4	SW01000	BoatshapedSwitch	1
5	ACV02001	ACVoltmeter	1
6	DCS03001	DCSocket	1
7	GB/T818-2000	Screw M4x30	4
8	GB/T6177.1-2000	Nut.M6	1
9	PL01	PVC Label	1
10	GB/T818-2000	Screw.M4x10	2
11	6700-09001	ControlPanel	1
12	GB/T5783-2000	Bolt M4x20	8
13	SW01001	Breaker	1
14	SC02010-1	Socket	2
15	GB/T6170-2000	Nut M4	8
16	EM1001	Quick-StopButton	1
17	SP02010-2	Plug	2



**Safety Instructions & Operator's
Manual SUITABLE FOR POWER PRODUCTS**